



true

GRILLO

P+F Parisotto+Formenton

GRILLO

P+F Parisotto+Formenton

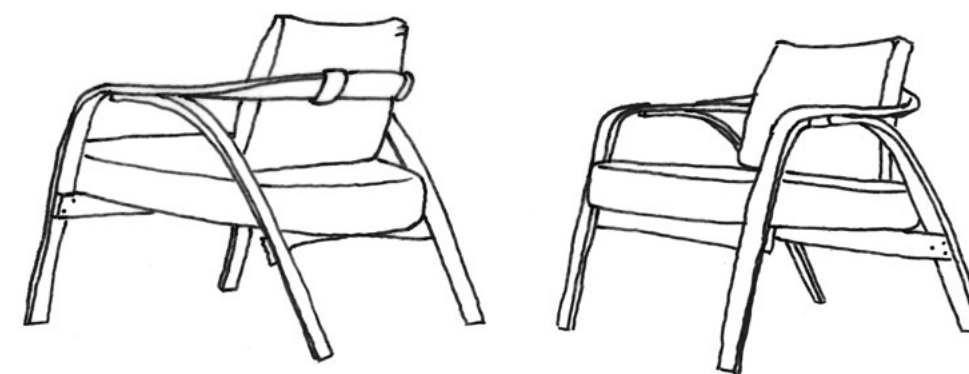

Grillo è caratterizzato dal contrasto tra la struttura, le zampe, dinamica e caratterizzata da curve tese ed archi contrapposti che si incontrano e la seduta che vi si inserisce come giustapposta.

Il nastro in lamellare termocurvato, senza mai cambiare la propria sezione ma solo attraverso delle calibrate torsioni, crea in continuità prima il piede, poi il bracciolo e lo schienale come un unico segno che si muove nello spazio. Grande valenza estetica ha il contrasto, con cui si può giocare, tra il colore e la caratterizzazione materica degli elementi in legno e di quelli imbottiti.

Grillo is defined by the contrast between the structure, the paws, dynamic and characterized by stretched curves and counterposed arches, gathering with the seat in between, juxtaposed.

The thermo curved wooden element, without ever changing its section but only through calibrated torsions, creates the foot, the armrest and the backrest as a unique line moving through the space. The contrast between the colors and the materials is the main aesthetic feature of this collection.





GR 1000

poltrona • armchair

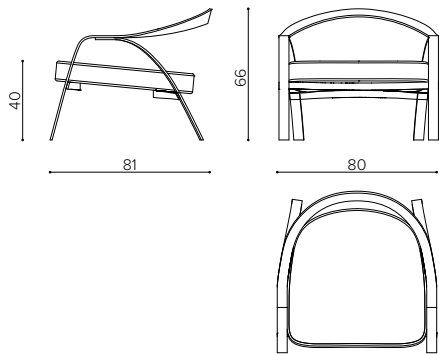
**GR 1050**

cuscino/backrest • cushion/backrest

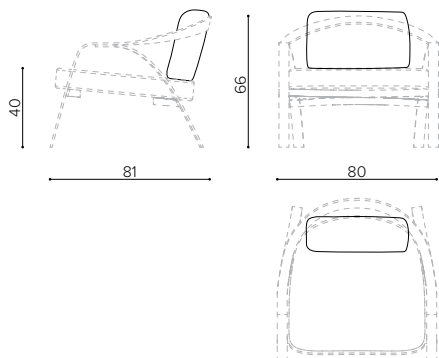
**COLORS****LEGNO / WOOD**

Le finiture standard del legno sono il faggio e rovere naturali o nero tinto all'anilina. Su richiesta sono disponibili altre colorazioni customizzate su tinta RAL.

**RAL**

Standard finishings for wood are natural oakwood and beechwood or black aniline dyed. Customized RAL colors are available upon request.

Direzione Artistica	Aldo Parisotto
Fotografia	Dario Breggiè
Progetto grafico	Antitetico
Progetto realizzato da	TRUE Design s.r.l.

true

TRUE DESIGN s.r.l.
Via Leonardo da Vinci 2
35040 S.Elena (PD) ITALY
t (+39) 0429 692483
f (+39) 0429 668018
info@truedesign.it
www.truedesign.it

sede legale/fatturazione
V.le della Repubblica 8
35043 Monselice (PD)
P.IVA C.F. 04428190286